

This model can be connected to the test sample in a few seconds.

With very low sensitivity to vibrations, this hot mountable unit is

ideal for the demanding requirements of strain controlled, elevated

temperature axial testing and other common test methods.

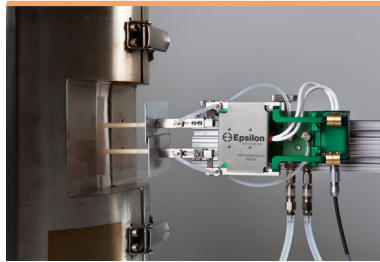

Model 3549 with a 25 mm gauge length shown with a split furnace



Model 3549 with 25 mm gauge length

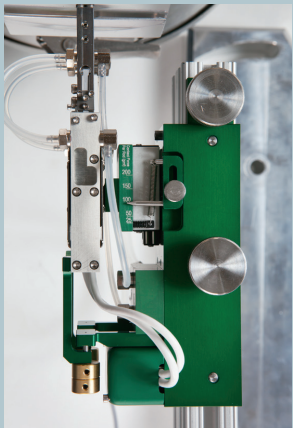

Model 3549 contact force scale for repeatable placement against test specimens

The Model 3549 is a major advancement in the design of externally mounted, furnace extensometers. This new extensometer is designed to meet the stringent requirements of strain controlled testing as prescribed in ISO 6892, while introducing many new innovative features that help improve productivity with static testing applications (tension and compression testing) and long term testing such as low cycle fatigue and creep. The overall design reduces any influence from common lab environment vibrations. This unit also incorporates a new feature that allows the user to precisely set the contact force against the test specimen. This allows for even and repeatable contact force, limiting contact force induced errors. This extensometer mounts on a slide bracket (included) that can attach to the load frame of your test system; optional load frame mounting brackets are available. The gauge length for the 3549 is automatically set prior to mounting on the test specimen, which allows for hot mounting after thermal equilibrium has been reached.

The Model 3549 standard temperature version is made for use in split type materials testing furnaces to 1200 °C (2200 °F) and includes water-cooled bracketry. The high temperature option allows use to 1600 °C (2900 °F). These extensometers can be used in carousel systems for rapid high temperature testing.

The standard temperature version (to 1200 °C) is supplied with high purity alumina rods. The high temperature option is furnished with alpha grade silicon carbide rods. Rods are made to order to the length required for your furnace. Mounting brackets may be integrated with the furnace cut-out. Epsilon can also provide load frame mounting brackets to fit your test frame.

The Model 3549 extensometers are strain gaged devices, making them compatible with any electronics designed for strain gaged transducers. Most often they are connected to a test machine controller. The signal conditioning electronics for the extensometer is typically included with the test machine controller or may often be added. In this case the extensometer is shipped with the proper connector and wiring to plug directly into the electronics. For systems lacking the required electronics, Epsilon can provide a variety of solutions, allowing the extensometer output to be connected to data acquisition boards, chart recorders or other equipment.

 See the Model 3549 extensometer videos

Features

- **May be left on through specimen failure.**
- Hot mountable and retractable.
- Designed for applications requiring greater than ± 2.5 mm (± 0.10 inches) full scale measuring range. For applications requiring smaller full scale ranges, see Model 7650A (page 30) or Model 3648 (page 28).
- Designed to meet the demanding requirements of strain controlled testing, such as required by ISO 6892, as well as more common testing. The 3549 is designed to isolate the strain sensing components from external vibrations.
- The gauge length is set automatically between each test with Epsilon's unique auto-setting mechanism, which allows the device to be mounted to the sample in seconds.
- The low contact force is easily controlled through the included contact force setting assembly. This allows for easy, repeatable placement of the extensometer on subsequent specimens with the same amount of force.
- Innovative slide mount allows the extensometer to engage the specimen once the test temperature has been achieved.
- All models can measure in both tension and compression and can be used for cyclic testing.
- The gauge length of the 3549 can be easily adjusted to virtually any gauge length through the use of gauge length spacers.
- The 3549 is designed to be used in carousel systems or with single furnaces.
- Mechanical overtravel stops in both directions.
- All units come with either high purity alumina ceramic rods (1200 °C) or alpha grade silicon carbide rods (1600 °C).
- The 3549 includes quick attach connectors for the water cooling lines and the electrical connections, which allow for easy installation of the extensometer body.
- Most standard units meet ASTM class B-1 requirements for accuracy. A test certificate is included. ISO 9513 class 0,5 test certificates are available upon request. Rod length configurations can affect the final class rating.
- Includes the Epsilon Shunt Calibration System for on-site electrical calibration.
- Rugged, dual flexure design for strength and improved performance.
- Full bridge, 350 ohm strain gaged design for compatibility with nearly any test system.
- Includes high quality foam lined case and a spare set of ceramic rods.

SPECIFICATIONS

Excitation:	5 to 10 VDC recommended, 12 VDC or VAC max.
Output:	1.5 to 2 mV/V nominal, depending on model
Linearity:	$\leq 0.15\%$ of full scale measuring range
Temperature Range:	Standard (-ST) is to 1200 °C (2200 °F), optional (-HT) 1600 °C (2900 °F)
Cable:	Integral, ultra-flexible cable, 2.5 m (8 ft) standard
Contact Force:	Adjustable from 50 to 400 g
Operating Force:	<30 g typical

OPTIONS

Model 2050 constant temperature water re-circulating bath
 High temperature option (-HT suffix) for use to 1600 °C
 Load frame mounting brackets
 Connectors to interface to nearly any brand of test equipment
 Specify rod tip style desired; available choices are straight chisel, vee chisel, or conical tip

ORDERING INFORMATION

Model 3549 Available Versions: ANY combination of gauge length, measuring range and temperature range listed below is available, except as noted. *Other configurations may be available with special order; please contact Epsilon to discuss your requirements.*

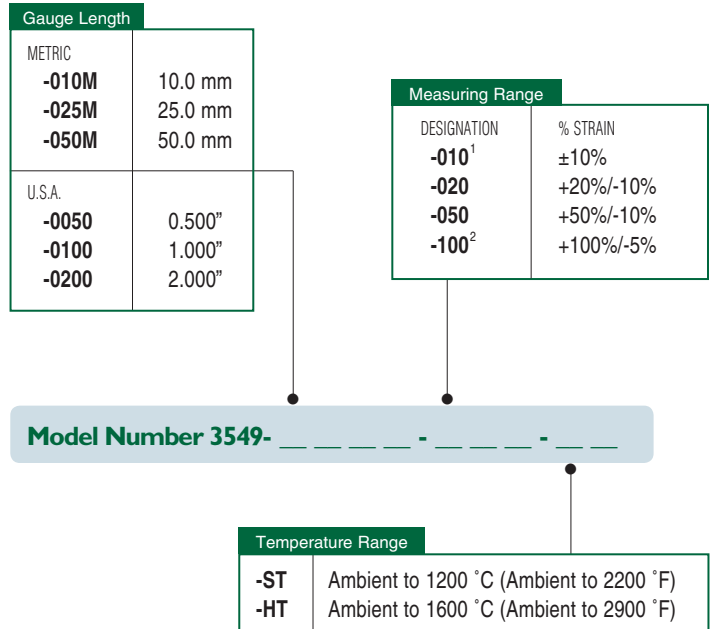

¹ Not available in 10 mm, 12.5 mm, or 0.5 inch gauge lengths.

² Not available in 50 mm or 2 inch gauge lengths.

Example: 3549-025M-050-HT: 25 mm gauge length, +50%/-10% measuring range, high temperature option (room temperature to 1600 °C)

Visit our website at www.epsilontech.com
 Contact us for your special testing requirements.

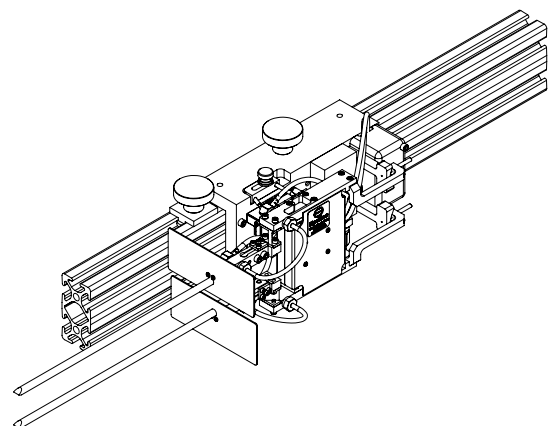

MODEL 3549 EXAMPLE