

Recd. dt. 02/05/2011

**SOLD & SERVICED BY**



**KRUTAM ENTERPRISES**

64/B, G.I.D.C., Makarpura, Baroda-10.  
 Ph.(0265) 2640767 / 3047424 Fax : (0265) 2651828  
 E-mail : krutam@krutam.com  
 krutam.nirmal@gmail.com  
 web site : www.krutam.com

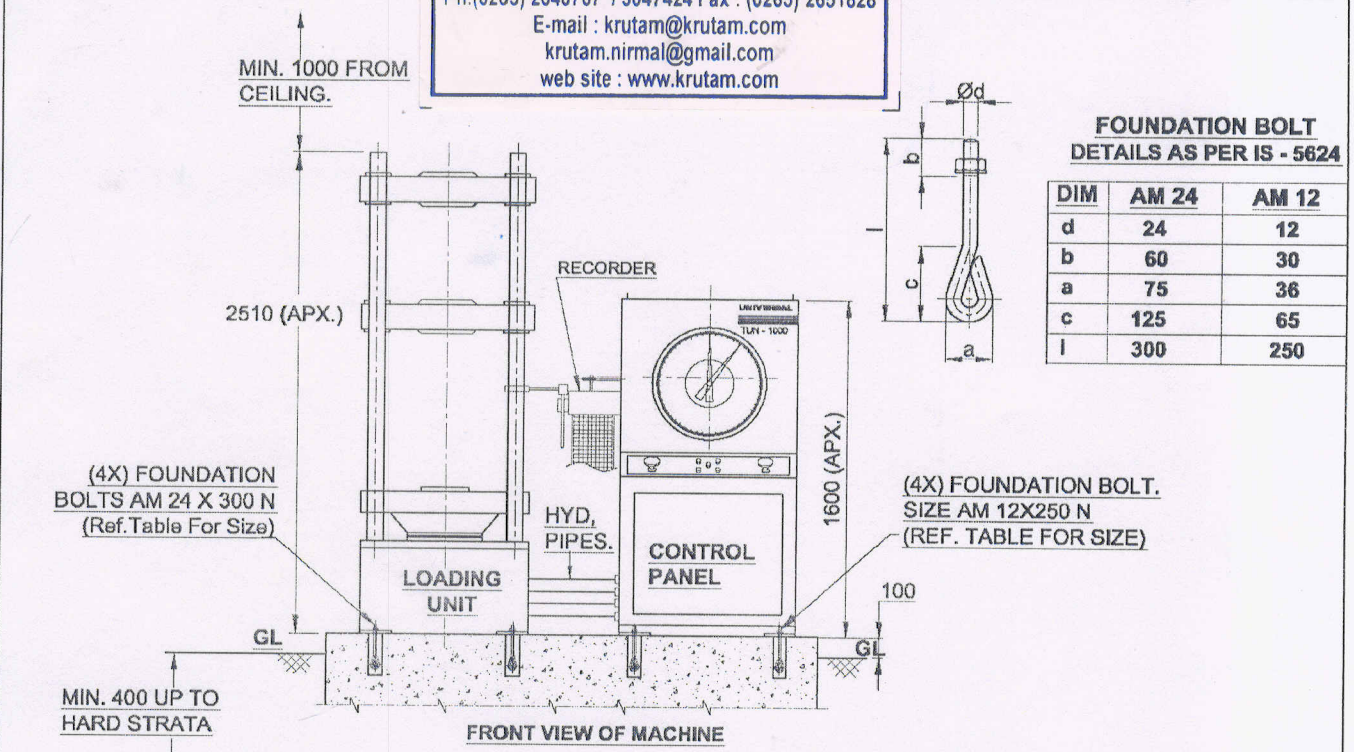

**FOUNDATION BOLT DETAILS AS PER IS - 5624**

DIM	AM 24	AM 12
d	24	12
b	60	30
a	75	36
c	125	65
l	300	250

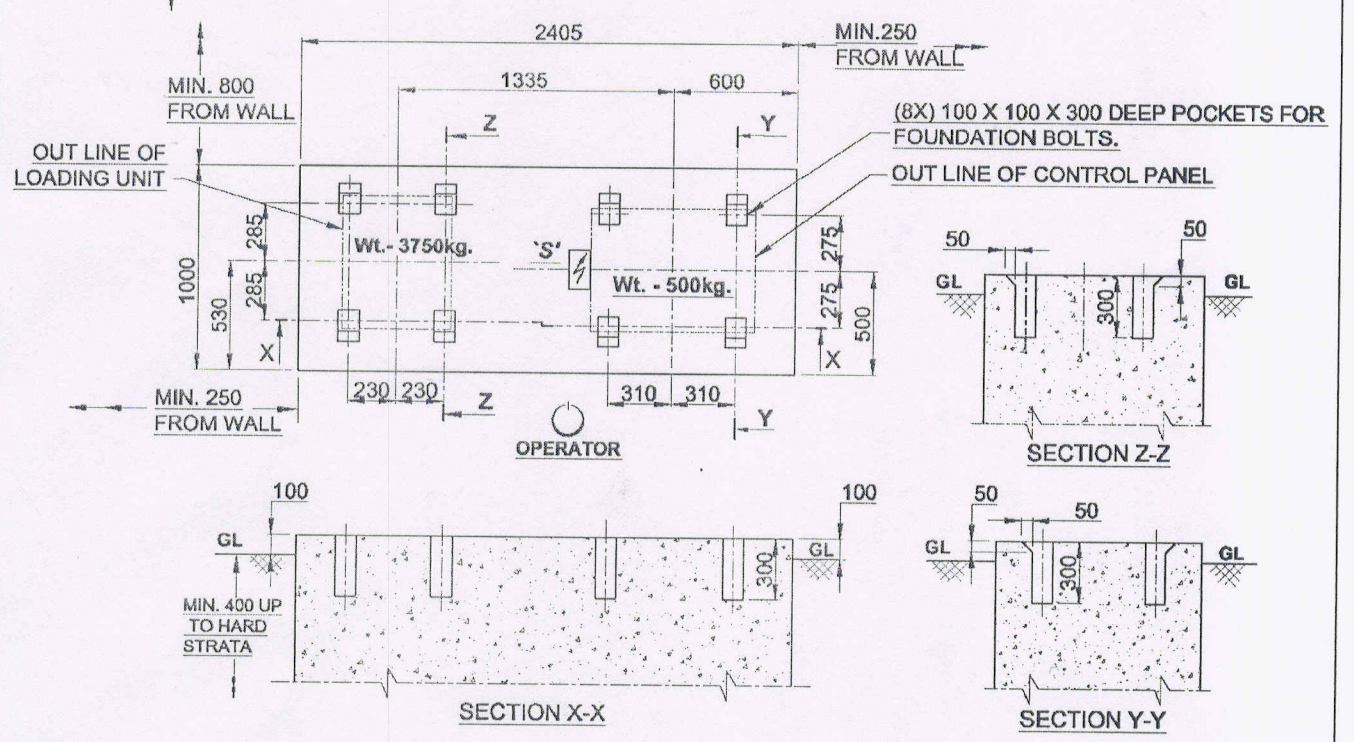

**NOTE :-**  
 1) ALL DIMENSIONS ARE IN mm.  
 2) 'S' ELECTRIC SUPPLY POINT LOCATION. (3 PHASE, 440 V, 50 CYCLE, A.C.)

**\* UNIVERSAL TESTING MACHINE \*  
 FOUNDATION PLAN**

**MODEL - TUN-1000**  
 DRN :- PRANOTI, DATE :- 09.08.2010, CHK :- Y.V.Kulkarni

**Fine Spavy Associates And Engineers**  
 Pvt. Ltd. C-45-2 M.I.D.C. Miraj. 